

# HIGHWIRE QUAD

## INSTALLATION GUIDE

### Where to use HIGHWIRE QUAD

HIGHWIRE QUAD makes it possible to replace an installed analogue camera with up to four high-quality digital IP cameras, without the expense of replacing existing cabling.

HIGHWIRE QUAD integrates a HIGHWIRE Ethernet-over-coax interface, a 10/100 network switch, and a versatile Power Over Ethernet (POE) supply, into a single wall-mountable device.

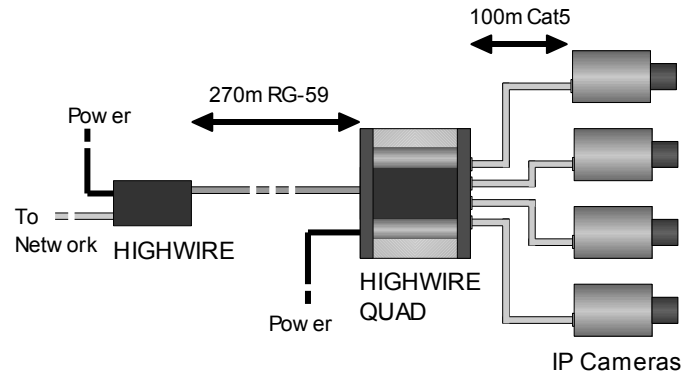

In the example above, the HIGHWIRE QUAD provides all four cameras with both a POE power supply and Fast Ethernet connection, and converts the data into a digital signal that can be carried by the existing coaxial video cable.

A single-port HIGHWIRE converts the digital signal back to an Ethernet connection at the other end of the cable, allowing the cameras to communicate with the rest of the network. The HIGHWIRE conversion is transparent and undetectable to the network.

### Connection diagrams

Connections to the HIGHWIRE QUAD are as shown:

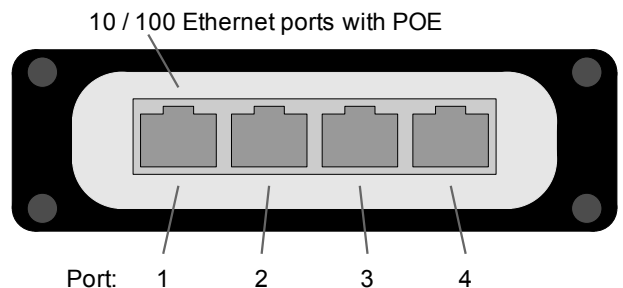
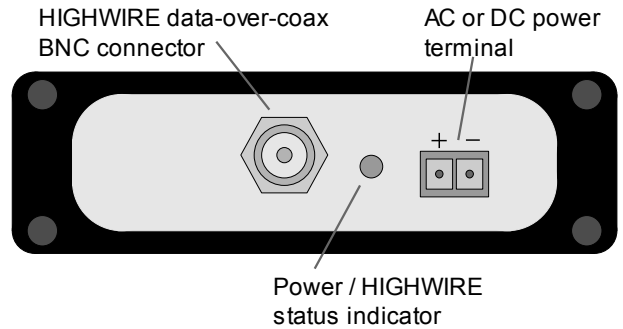

Please read the installation instructions overleaf carefully before installing your HIGHWIRE QUAD.



#### EC Declaration of Conformity

In accordance with EN 45014:1998

We, Veracity UK Ltd. of 6 Barns Street, Ayr, KA7 1XA declare that the equipment "HIGHWIRE QUAD" Data Converter model number VHW-HWQ

conforms to the essential protection requirements of the EMC Directive 89/336/EEC as amended. The following EMC standards have been applied:

BS EN 55022:1998 Emissions (Class B Radiated)

BS EN 55024:1998 Immunity (BS EN 61000-4-2:1995 Immunity to ESD, BS EN 61000-4-3:2000 Immunity to Radiated RF Fields (3V/m))

I hereby declare that the equipment named above has been found to comply with the relevant sections of the above referenced specifications. The unit complies with all essential requirements of the EMC Directive.

Responsible Person *Alastair McLeod* Mr Alastair McLeod, Director

Issued 2008 at Ayr



This device complies with Part 15 of the FCC Rules. Operation is subject to the following two conditions: (1) this device may not cause harmful interference, and (2) this device must accept any interference received, including interference that may cause undesired operation.

NOTE: This equipment has been tested and found to comply with the limits for a Class A digital device, pursuant to Part 15 of the FCC Rules. These limits are designed to provide reasonable protection against harmful interference when the equipment is operated in a commercial environment. This equipment generates, uses, and can radiate radio frequency energy and, if not installed and used in accordance with the instruction manual, may cause harmful interference to radio communications. Operation of this equipment in a residential area is likely to cause harmful interference in which case the user will be required to correct the interference at his own expense.

# Installation

## Mounting holes

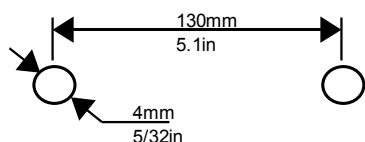

HIGHWIRE QUAD is fitted with two repositionable mounting lugs to allow the unit to be secured to a wall. The recommended mounting hole locations are shown above.

The enclosed rubber feet may be fitted if the unit is to be located on a shelf.

## Earth connection

The case should be connected to earth before any data or power cables are connected. The earth connection can be made via the mounting lugs or by a cable secured to the BNC connector nut.

Earthing equipment at both ends of the coaxial cable prevents damage due to "ground loops", where there is a difference in earth voltage level between different locations.

If a high earth voltage difference is present, inline ground isolator VHW-XF should be fitted to the coaxial cable.

## Power supply connection

HIGHWIRE QUAD has a detachable screw terminal connector and will automatically configure for DC or AC supplies in the range 10 to 40V (DC) or 20 to 28V (AC).

A Class II isolated power supply with the "double insulated" logo (shown right) should be used.



The power supply used should be rated at 40 Watts or greater to guarantee power availability for all combinations of connected devices.

Part no VQ-24V-xx (xx=country code) is a 24V DC power supply and is recommended for use with HIGHWIRE QUAD.

## Long power cables

If the HIGHWIRE QUAD is to be located remotely from its power supply, care should be taken to select the right cable. Veracity can provide a spreadsheet tool for calculating the required cable gauge for given distances and loads.

## Thermal considerations for high loads

HIGHWIRE QUAD can become hot in operation and adequate space should be provided around the unit for ventilation. Heating increases with higher loads from POE devices, and also with lower supply voltage.

A 24 Volt supply such as VQ-24V-xx will give best performance and should be used when the total POE load is greater than 20 Watts or when the ambient temperature exceeds 35°C (95°F).

## HIGHWIRE connection

The following table gives typical maximum achievable range for full data rate connections over 75 Ohm coaxial cable:

Cable	Range (m)	Range (ft)
RG-59	270	900
RG-6	350	1170
RG-11	490	1630

The HIGHWIRE connection can adapt to greater distances by automatically reducing its maximum data rate. However, this

mode of operation is not recommended for HIGHWIRE QUAD.

The HIGHWIRE LED indicates the connection status as follows:

LED Pattern	Power	HIGHWIRE link
Off	No power	n/a
Short blink	Power good	No connection
Flashing	Power good	Reduced rate
On	Power good	Full rate

## Ethernet connection

HIGHWIRE QUAD will automatically configure its network ports for 10Base-T or 100Base-T, half or full-duplex operation, and either patch or crossover cables may be used.

The yellow network connector LEDs indicate network connection status per port as follows:

LED Pattern	Ethernet status
Off	No link
Flashing	Link good, network activity
On	Link good

## POE Power Management

The green network connector LEDs indicate Power Over Ethernet status per port as follows:

LED Pattern	POE status
Off	No POE requested
4 flashes / second	POE disabled: port error
1 flash / second	POE disabled: power budget exceeded
On	POE enabled to port

If a port error is indicated, check the network cable for open connections or short circuits, and ensure the POE equipment is IEEE 802.3af compliant and functioning correctly.

If the power budget has been exceeded then there is not enough power available to safely enable all connected POE devices.

HIGHWIRE QUAD has an available power budget of 30 Watts, which it can allocate to POE devices according to their Power Class. POE devices can indicate their required power as follows:

Power Class	Max Device Power (approx)
0 (unclassified)	15 Watts
1	4 Watts
2	7 Watts
3	15 Watts

For example, an IP camera which draws 5 Watts will usually be a Class 2 device, so it would "use" 7 Watts of the HIGHWIRE QUAD's power budget when connected.

Some devices do not display a power class however, and must be allocated the maximum 15 Watts, so only two such devices could be enabled. The manufacturer's information for each POE device should therefore be checked when planning an installation.

On power-up, HIGHWIRE QUAD will enable POE to ports 1,2,3 and 4 in that order, and thereafter as devices are connected.

Operating a HIGHWIRE QUAD with any POE devices disabled is not recommended, as a different combination of devices may be re-enabled following a power outage or device fault. If extra budget is required, an alternative POE supply such as Veracity's OUTSOURCE may be used to upgrade one or more ports.